

CONNECTORS; WETMATE, 4-POLE.
 BULKHEAD: MC-BH-4-M-SS, STAINLESS STEEL/MOLDED NEOPRENE, SEALING; 340 BAR OPEN FACE, 600 BAR MATED.
 IN-LINE: MC-IL-4-F, MOLDED NEOPRENE WITH CABLE. LOCKING SLEEVE; MCDLS-F, DELRIN.

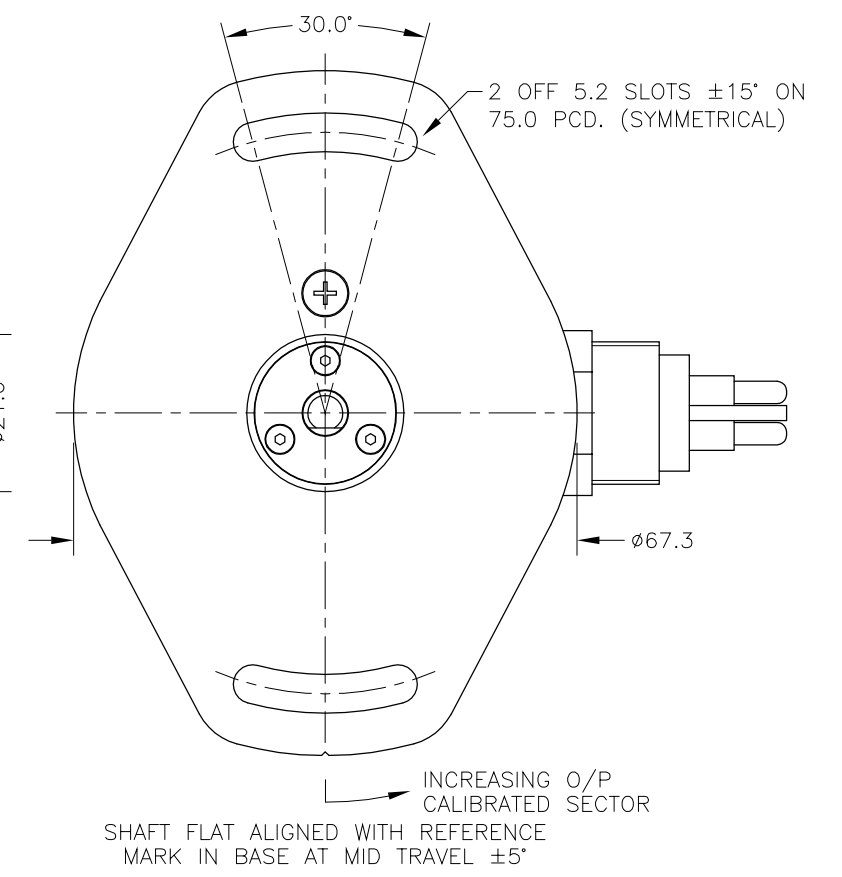
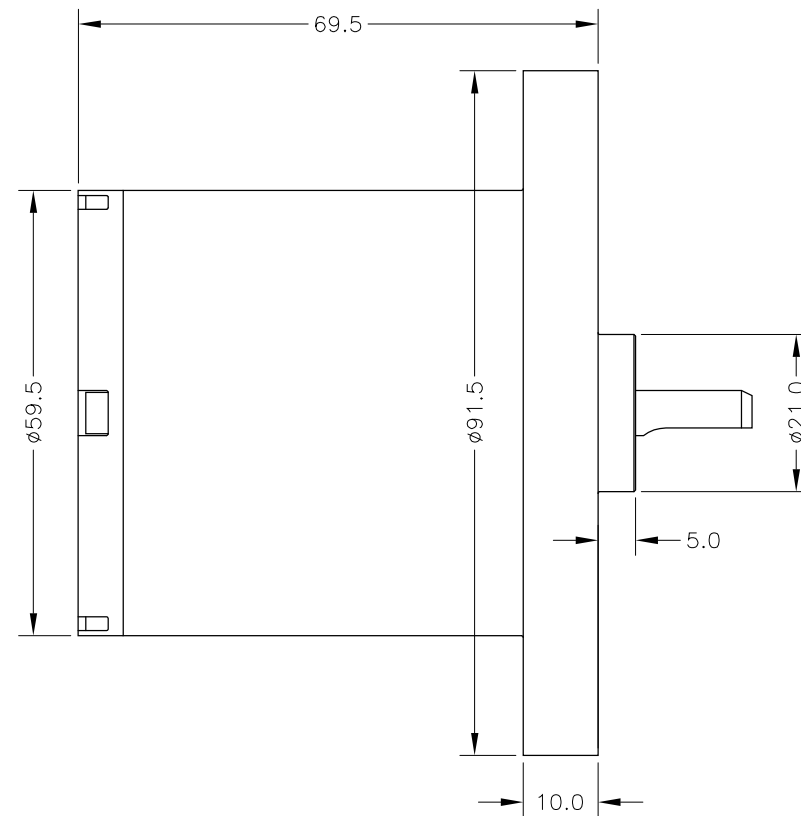
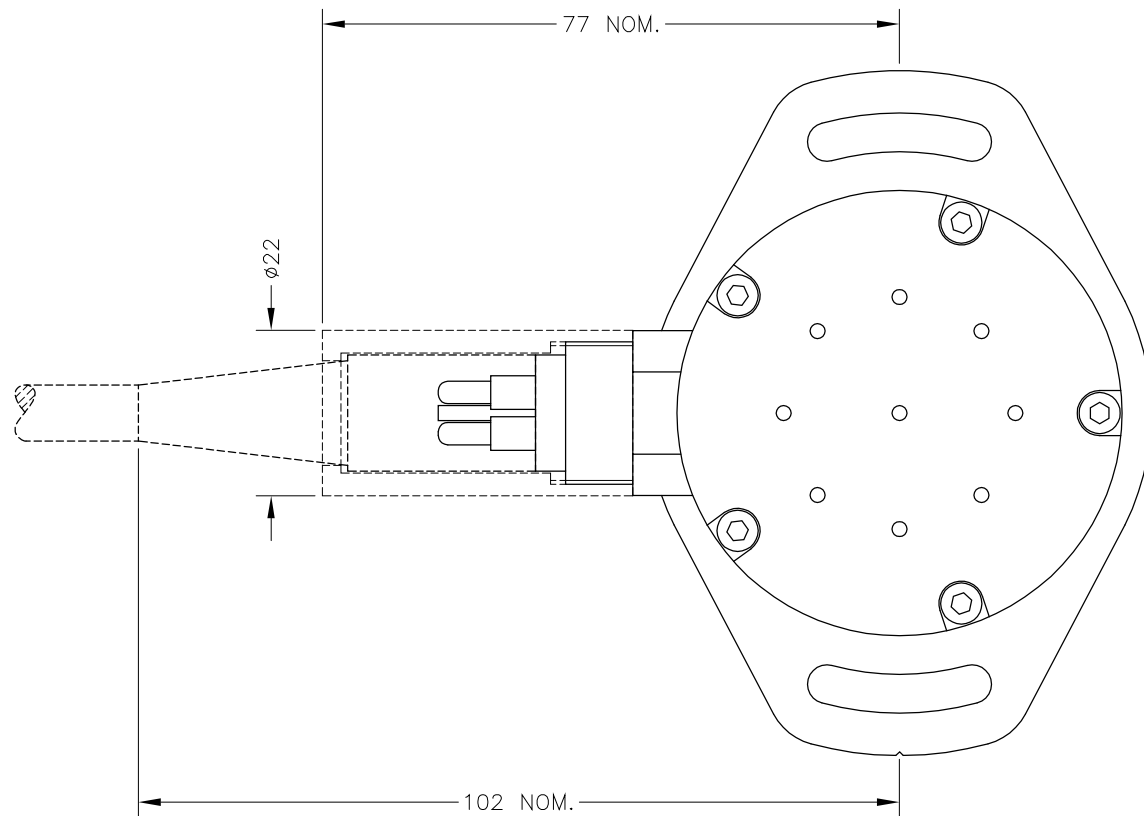

ELECTRICAL OPTIONS/ SPECIFICATIONS

OUTPUT	SUPPLY
0.5 TO 4.5V RATIO METRIC	5V
SUPPLY CURRENT 12mA TYP. 20mA MAX.	

MATING CONNECTOR SUPPLIED WITH 50cm MOULDED CABLE AS STANDARD.
 4-CORE SCREENED: 0.5mm², Ø7.5mm MAX. JACKET / CORE INSULATION: EPDM.

CONNECTIONS:-

1	BLACK	OUTPUT
2	WHITE	OV
3	RED	BODY
4	GREEN	+Ve
SCREEN NOT CONNECTED TO SENSOR		

RANGE OF DISPLACEMENT FROM 15° TO 160°, IN INCREMENTS OF 1°.
 BODY MATERIAL:- STAINLESS STEEL 316.

NOTE:- READ INSTALLATION SHEET X520-19 FOR FULL INSTRUCTIONS FOR USE.

ATEX / IECEx APPROVED TO
 Ex II 1G
 Ex ia IIC T4 Ga (Ta= -40° to +80°C)
 Ui 11.4V, li 0.2A, Pi 0.51W

APPROVED FOR USE IN CONJUNCTION WITH A GALVANICALLY ISOLATED BARRIER.

NOTE: APPROVAL ONLY APPLIES AT NORMAL ATMOSPHERIC PRESSURE!

N.b. CONNECTOR ORIENTATION NOT GUARANTEED.

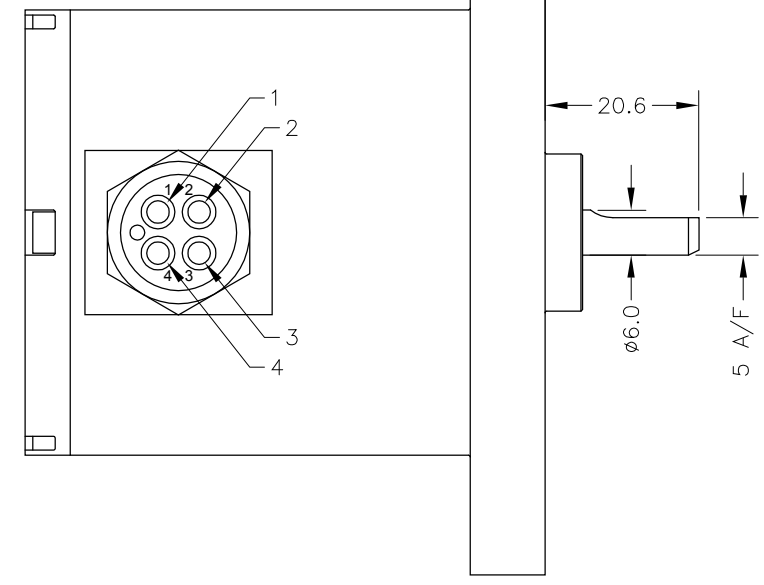

A	FIRST ISSUE.	PDM
B	DISP. FROM 15° WAS 16° - RAN1146	PDM
C	CABLE COLOURS CORECTED - RAN1190	PDM

MAXIMUM WORKING DEPTH: 3500 METRES 350 BAR. WHERE THE FREE END OF THE CABLE IS TO BE TERMINATED IN A SUBMERGED POSITION, ADEQUATE SEALING MUST BE PROVIDED TO PROTECT CONNECTIONS.
 SENSOR IS OIL FILLED AND PRESSURE BALANCED. PRESSURE SENSITIVITY <1%FS TO 350 BAR

DRAWINGS NOT TO BE CHANGED WITHOUT REFERENCE TO THE CHANGE PROCEDURE.
 CHANGES TO PARTS USED IN INTRINSICALLY SAFE PRODUCT MUST BE APPROVED BY THE AUTHORISED PERSON
 THIS IS AN UNCONTROLLED PRINT AND WILL NOT BE UPDATED.

Herbertek www.herbertek.se
 info@herbertek.se
 +46-18 590510



A	27/10/16		CHECKED BY	X ±0.4
B	12/12/16		RDS	X.X ±0.2
C	14/06/17			X.XX ±0.1 DIMS mm
DESCRIPTION		INTRINSICALLY SAFE 350 BAR SUBMERSIBLE ROTARY SENSOR		
SCALE 10mm		DRAWING NUMBER X520-11		REV C
				SHEET 1 OF 1