

- NOTES:
- GENERAL REQUIREMENTS
 - IN ACCORDANCE WITH SAE J1843
 - IN ACCORDANCE WITH FMVSS124
 - ENVIRONMENTAL DATA
 - WORKING TEMPERATURE: -40°C TO +85°C
 - STORAGE TEMPERATURE: -50°C TO +120°C
 - MECHANICAL DATA
 - STATIC FORCE APPLIED TO THE SURFACE OF THE PEDAL 150mm FROM THE PIVOT
 - INITIAL LOAD: 1.5 kg (MINIMUM)
 - FULL LOAD: 3.2 kg (MAXIMUM) (SEE FIGURE 3)
 - MAXIMUM LOAD: 160±5 kg
 - ELECTRICAL DATA
 - INPUT VOLTAGE (VCC): 5 Vdc±2%
 - OPERATING CURRENT (IOP): NO MORE THAN 10ma
 - ELECTRICAL TRAVEL: SEE FIGURE 2
 - LINEARITY: 2%
 - CONNECTOR: AMP J SERIES 6 WIRE 174264-2 (PLUG)
 - MATERIAL
 - PEDAL: PA66-GF30
 - BOTTOM PLATE: ADC12 CAST ALUMINUM
 - WIRE: AEX OR AVX 0.5 mm²
 - DURABILITY
 - LIFE CYCLE TEST: 3,000,000 CYCLES AT A FREQUENCY OF 60 TIMES PER MINUTE
 - ENVIRONMENTAL TEST: SEE FIGURE 4

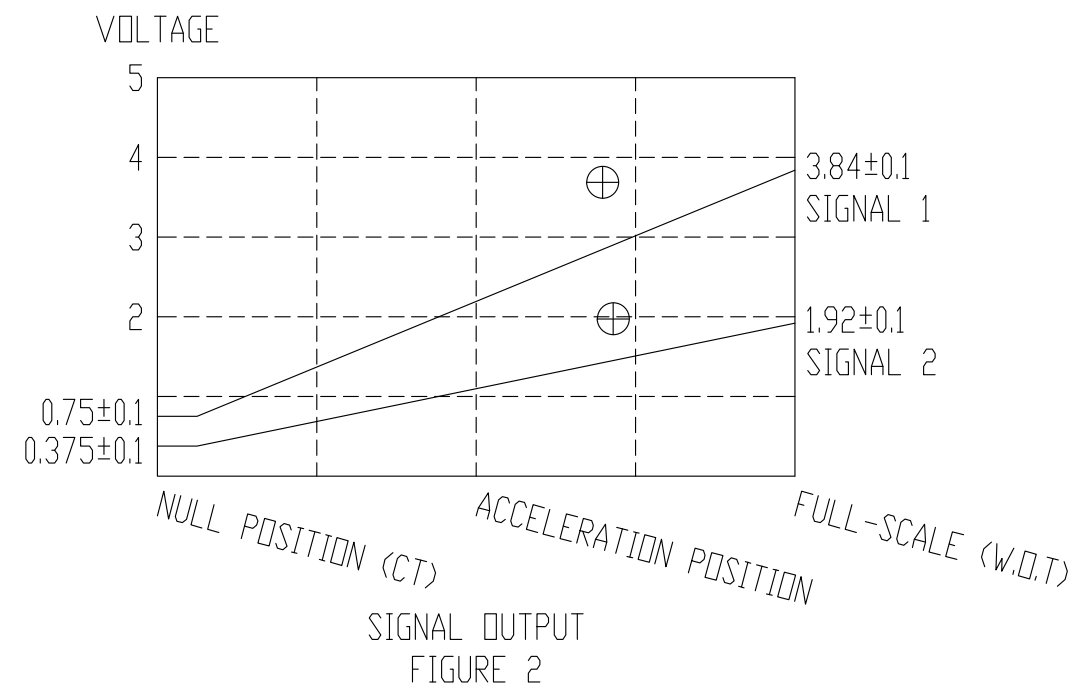

⊕ SIGNAL1 AND SIGNAL2 SYNCHRONOUS DEVIATION (SY) SY=(SIGNAL1/2) - SIGNAL2=±0.05V

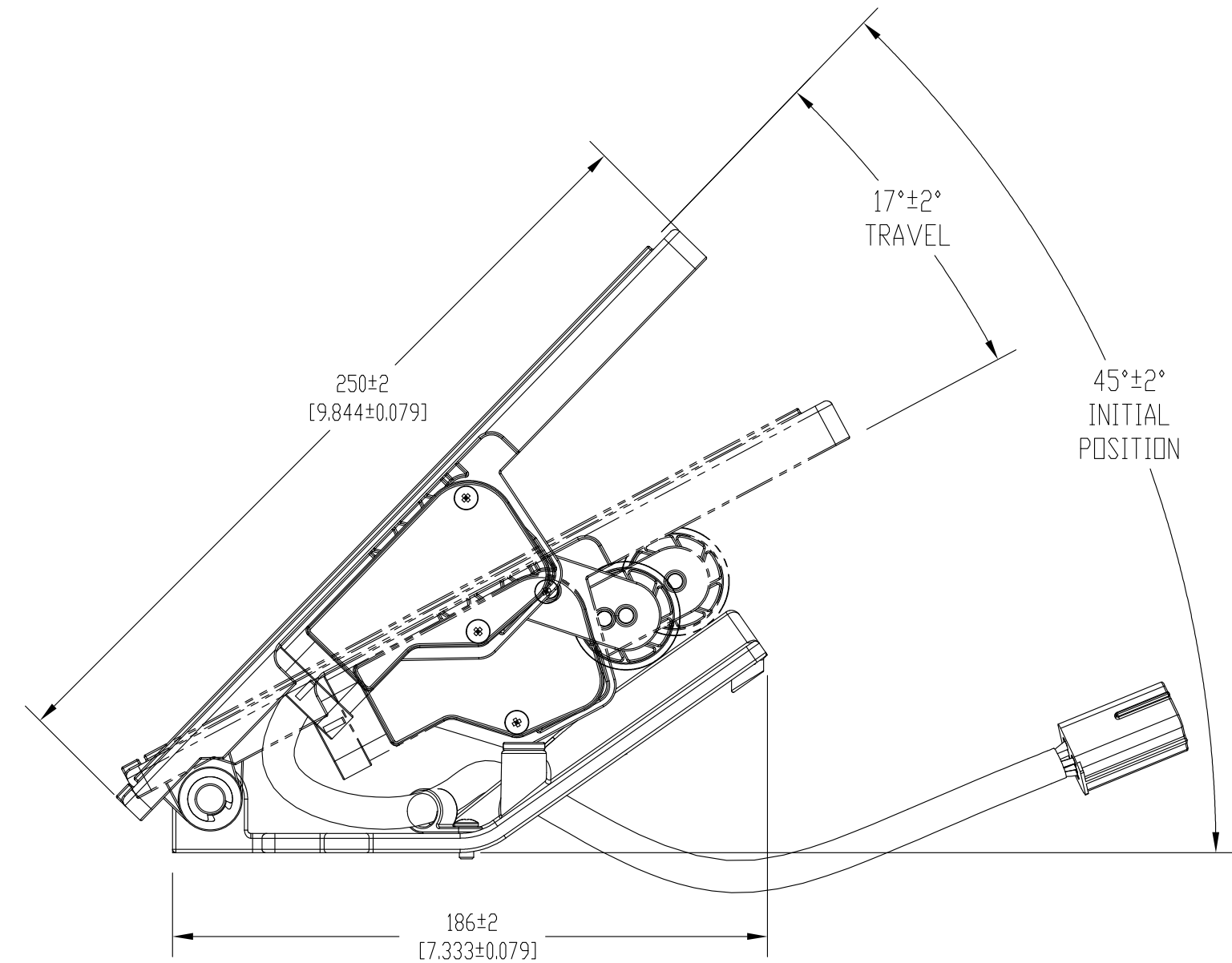
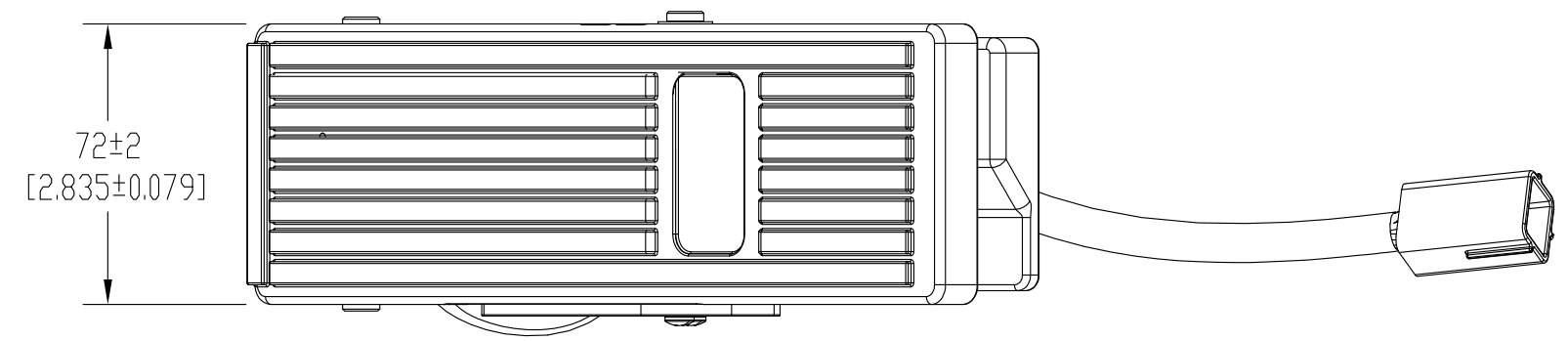
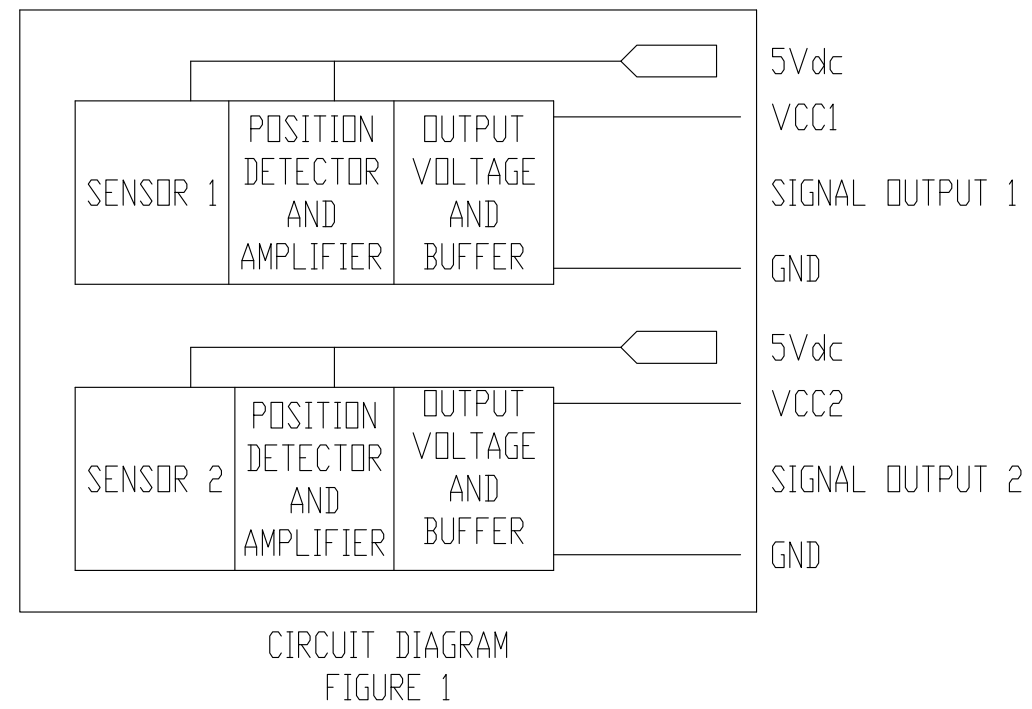
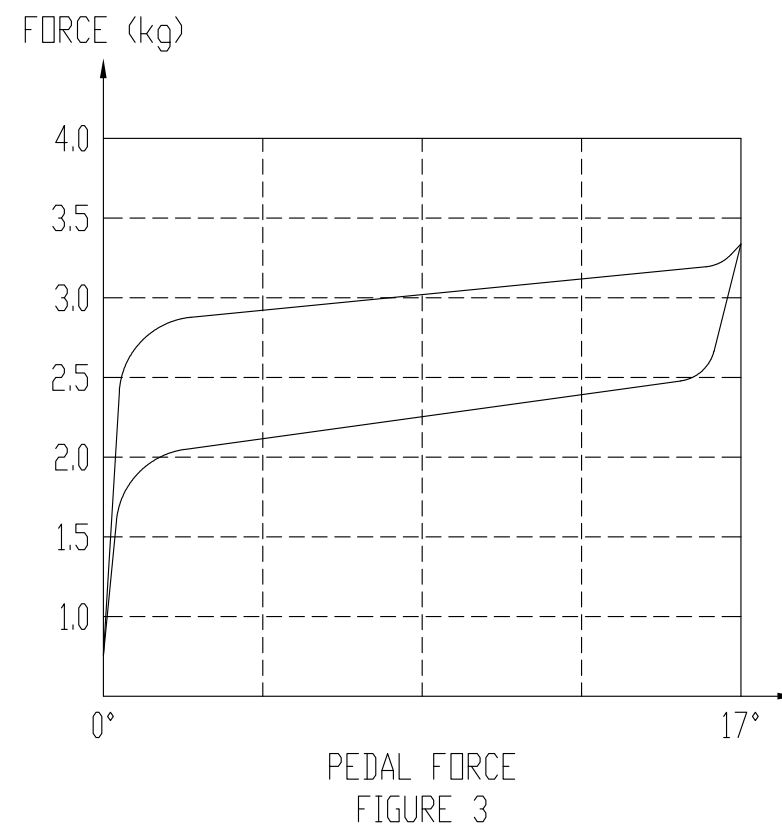
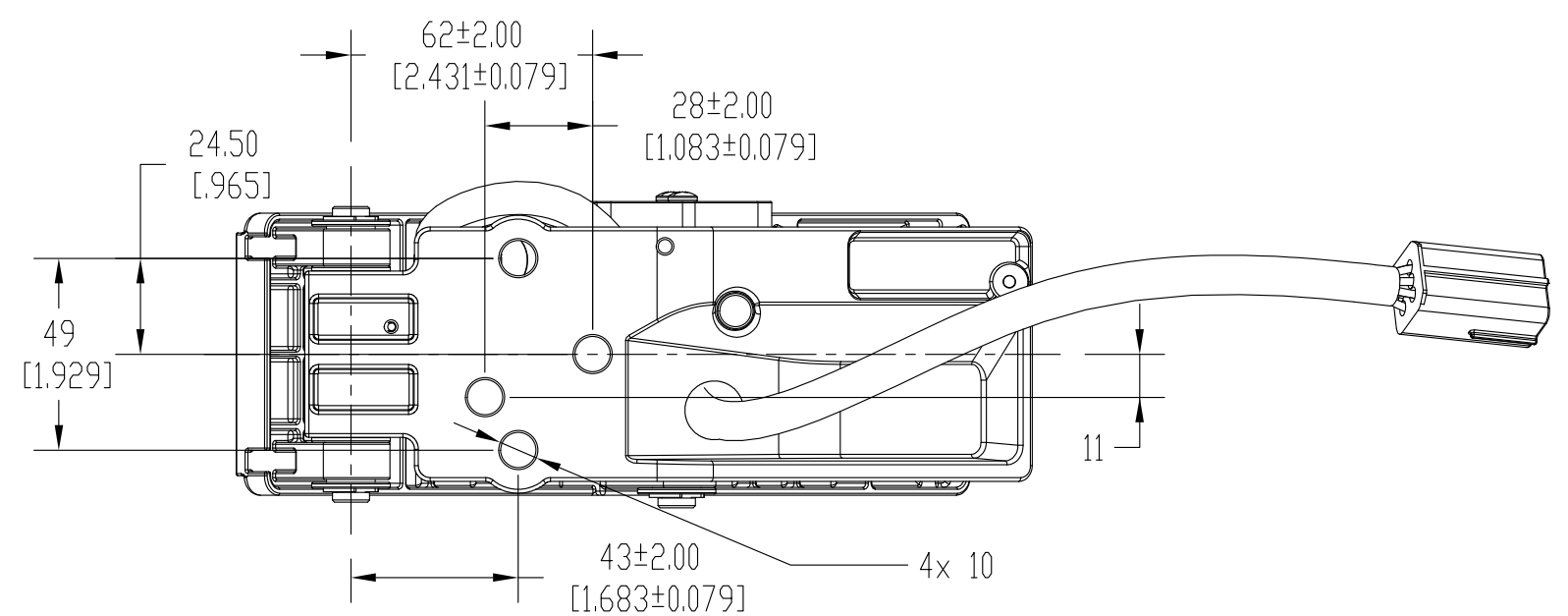

ENVIRONMENTAL TESTING
FIGURE 4

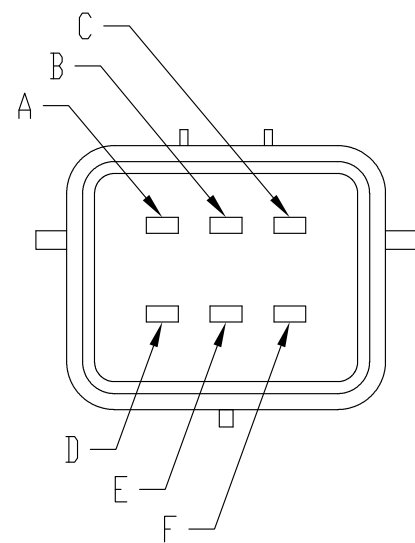

PIN	FUNCTION	COLOR
A	VCC1	RED
B	VS1	GREEN
C	GND1	BLACK
D	VCC2	YELLOW
E	VS2	BLUE
F	GND2	WHITE

ELECTRICAL PINOUT

AMP MODEL: 174264-2 (PLUG)
MATCHING MODEL: 174262-2 (SOCKET)

Herbertek www.herbertek.se
info@herbertek.se
+46-18 590510

UNITS IN millimeter [inch]

PART #

10456-0-M18-0877

SPECIFICATIONS:

1. GENERAL REQUIREMENTS

- IN ACCORDANCE WITH SAE J1843
- IN ACCORDANCE WITH FMVSS124

2. ENVIRONMENTAL DATA

- WORKING TEMPERATURE: -40°C TO +85°C
- STORAGE TEMPERATURE: -50°C TO +120°C

3. ELECTRICAL DATA

- INPUT VOLTAGE: 5.0V ±0.1
- MAXIMUM CURRENT: ≤ 10mA
- INDEPENDANT LINEARITY: 2%
- OUTPUT SIGNALS: SEE FIGURE 1

4. MECHANICAL DATA

- MAXIMUM LOAD: 160±5 kgf

5. MATERIAL

- PEDAL: BLACK NYLON 6/6 30% GLASS FILLED
- BOTTOM PLATE: ZINC PLATED STEEL
- WIRE: AEX OR AVX 0.5 mm²

6. DURABILITY

- LIFE CYCLE TEST: 10,000,000 CYCLES AT A FREQUENCY OF 60 TIMES PER MINUTE

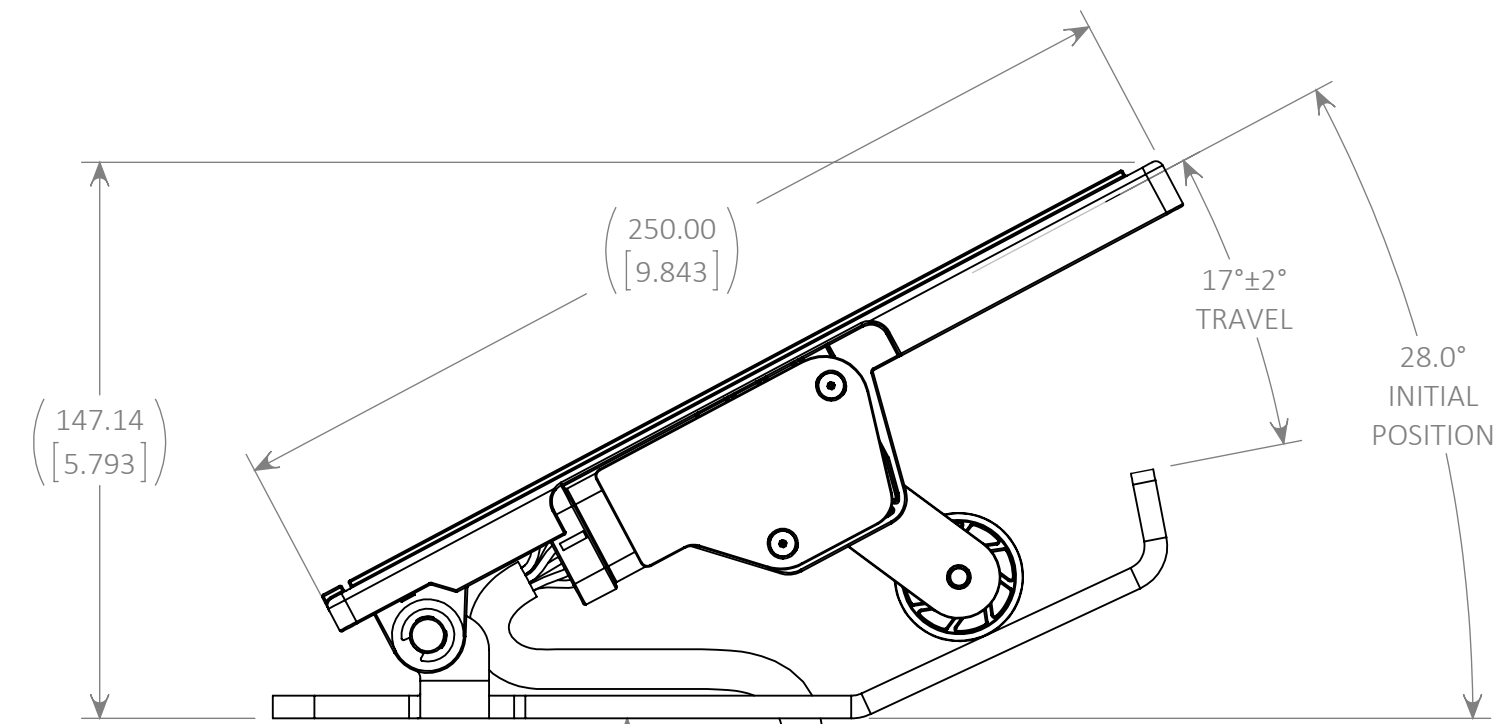
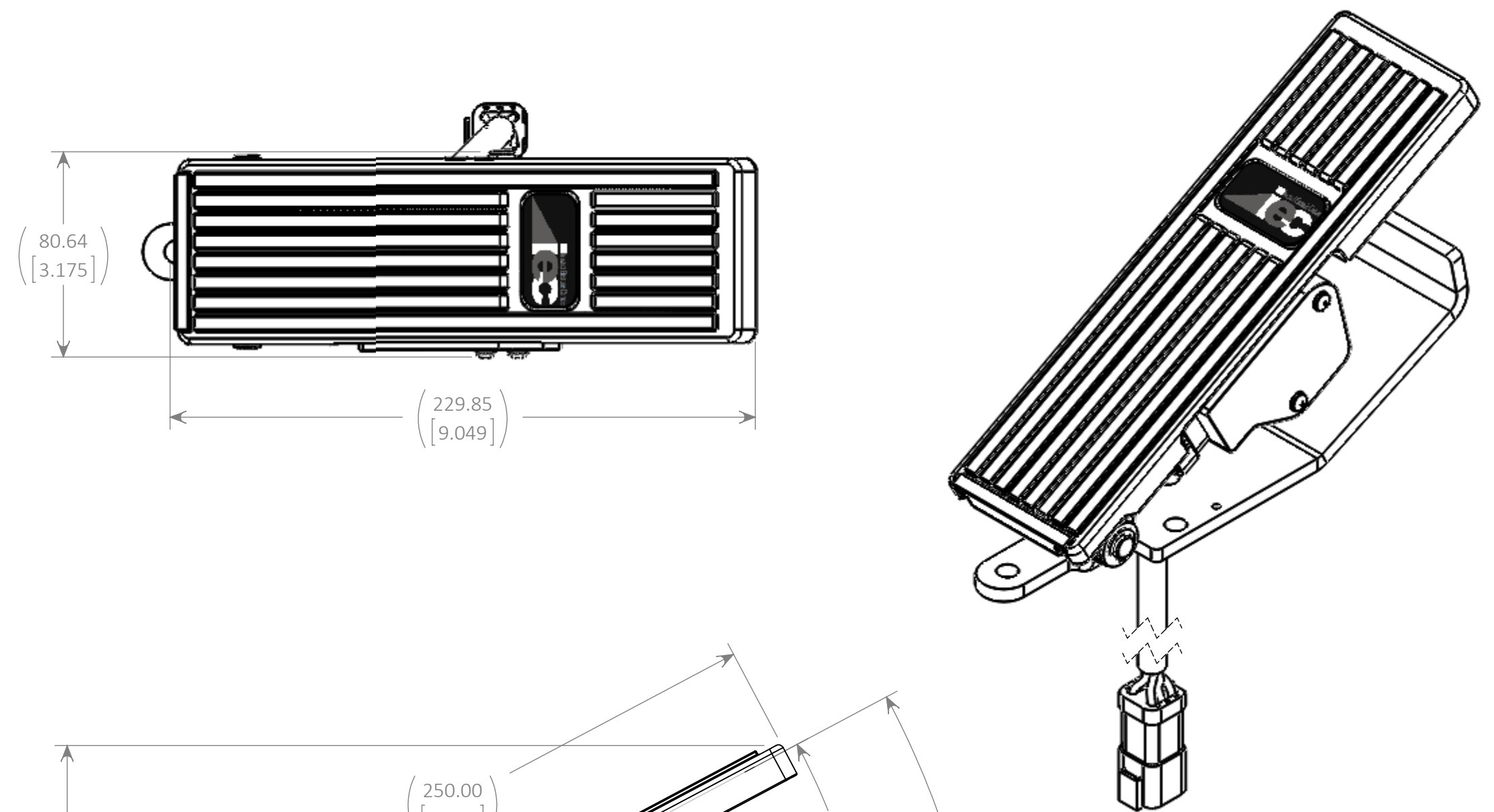

CONNECTOR: DEUTSCH DT04-6P
BOOT: DT6P-BT

WIRE TABLE			
POSITION	SIZE	COLOR	FUNCTION
1	20	RED	VCC1
2	20	BLACK	OUT1
3	20	WHITE	GND2
4	20	BLUE	NC
5	20	GREEN	NO
6	20	ORANGE	VCC2

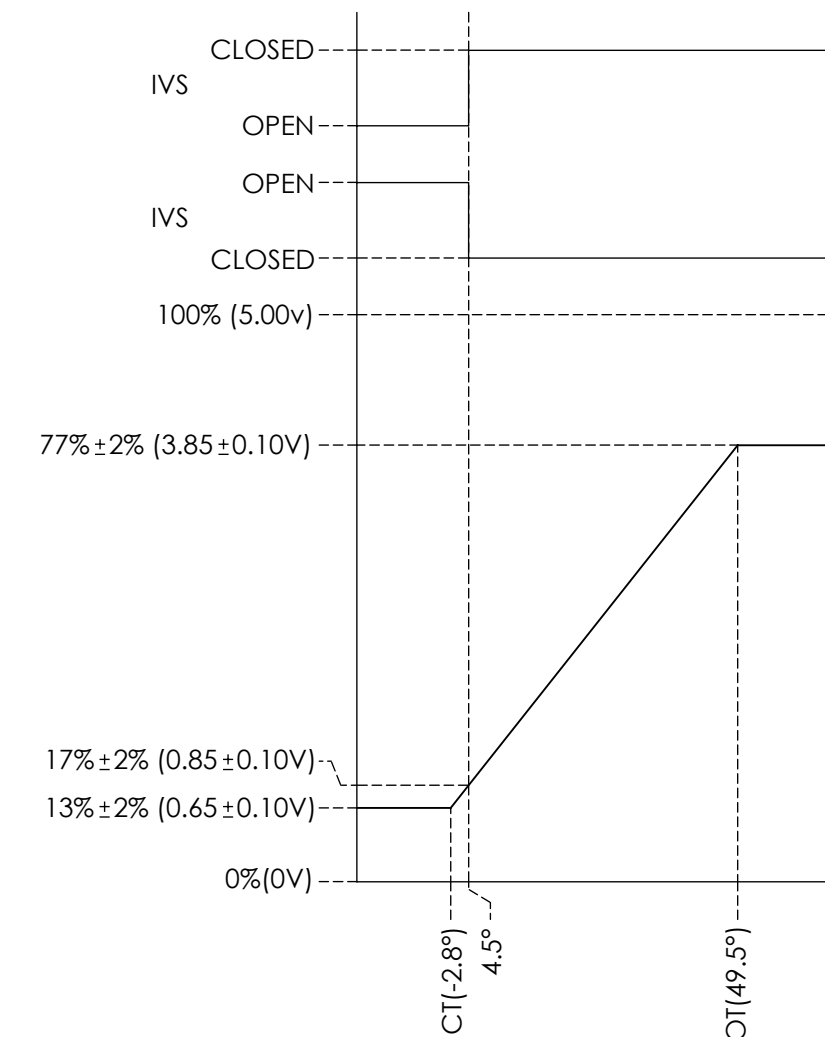

**SENSOR ELECTRICAL OUTPUT
FIGURE 1**

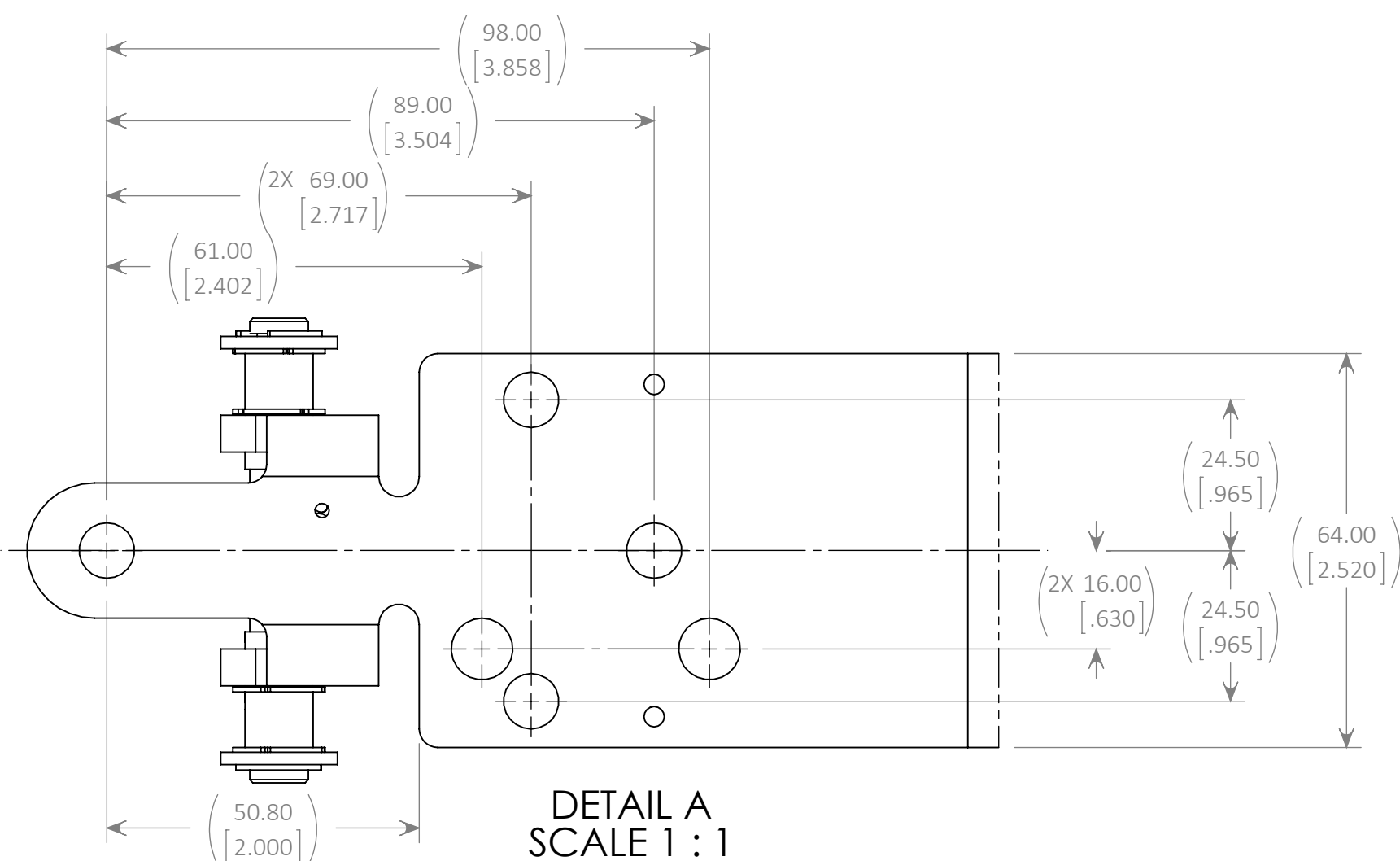

**DETAIL A
SCALE 1 : 1**

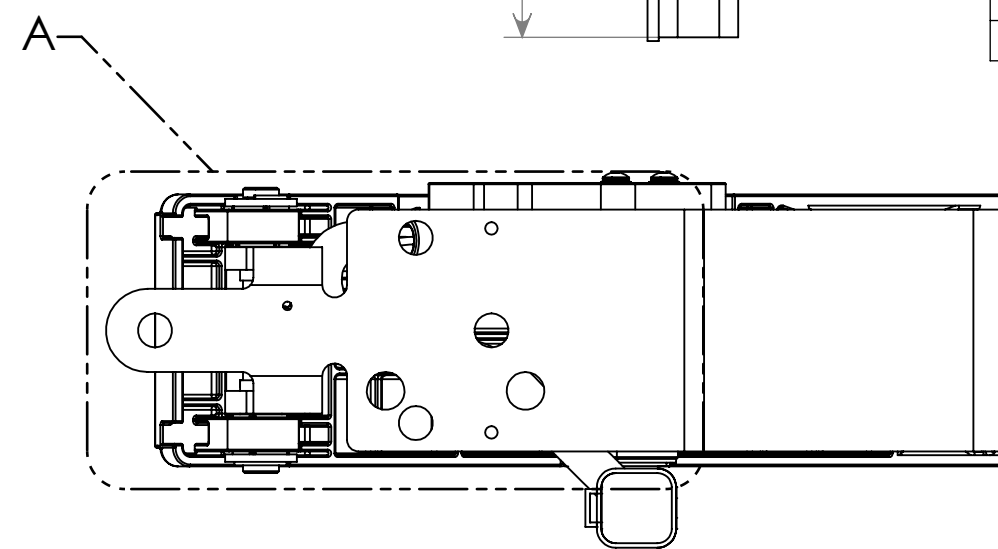

Herbertek www.herbertek.se
info@herbertek.se
 +46-18 590510

UNITS IN millimeter [inch]

PART #
10456-28P-711D-S1377

SPECIFICATIONS:

1. GENERAL REQUIREMENTS
 - IN ACCORDANCE WITH SAE J1843
 - IN ACCORDANCE WITH FMVSS124

2. ENVIRONMENTAL DATA
 - WORKING TEMPERATURE: -40°C TO +85°C
 - STORAGE TEMPERATURE: -50°C TO +120°C

3. ELECTRICAL DATA
 - INPUT VOLTAGE: 5.0V ±0.1
 - MAXIMUM CURRENT: ≤ 10MA
 - INDEPENDANT LINEARITY: 2%
 - OUTPUT SIGNALS: SEE FIGURE 1

4. MECHANICAL DATA
 - MAXIMUM LOAD: 160±5 KGF

5. MATERIAL
 - PEDAL: BLACK NYLON 6/6 30% GLASS FILLED
 - BOTTOM PLATE: ZINC PLATED STEEL
 - WIRE: AEX OR AVX 0.5 mm²

6. DURABILITY
 - LIFE CYCLE TEST: 10,000,000 CYCLES AT A FREQUENCY OF 60 TIMES PER MINUTE

7. PEDAL FORCE REQUIREMENTS:
 - 5LBS TO START MOTION
 - 12LBS MAX AT FULL TRAVEL

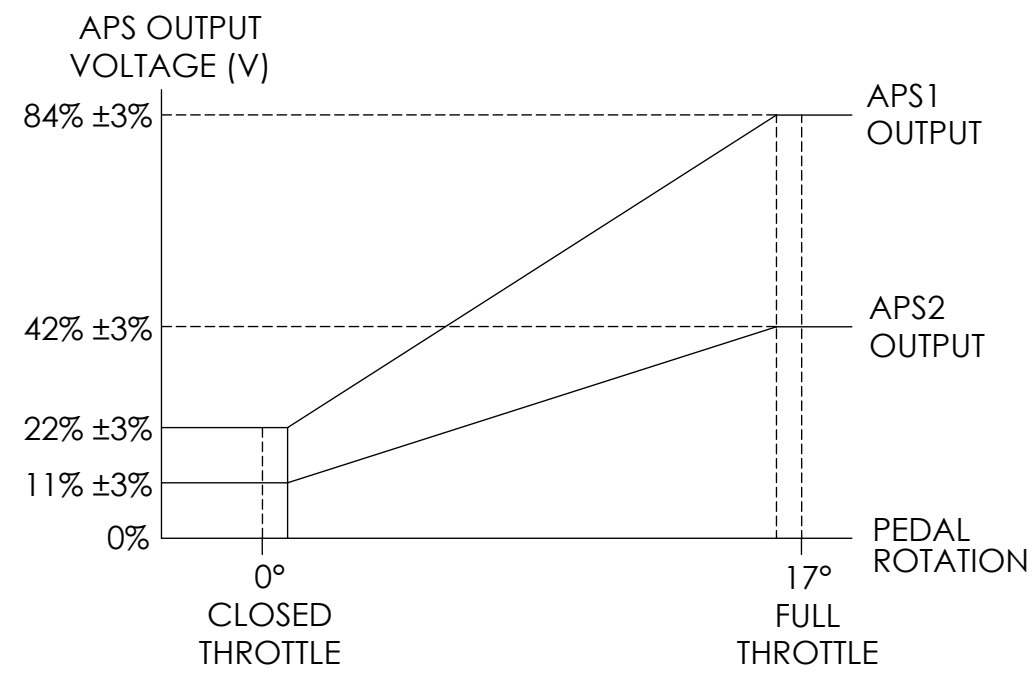

TYPICAL OUTPUT CHARACTERISTICS
 FIGURE 1

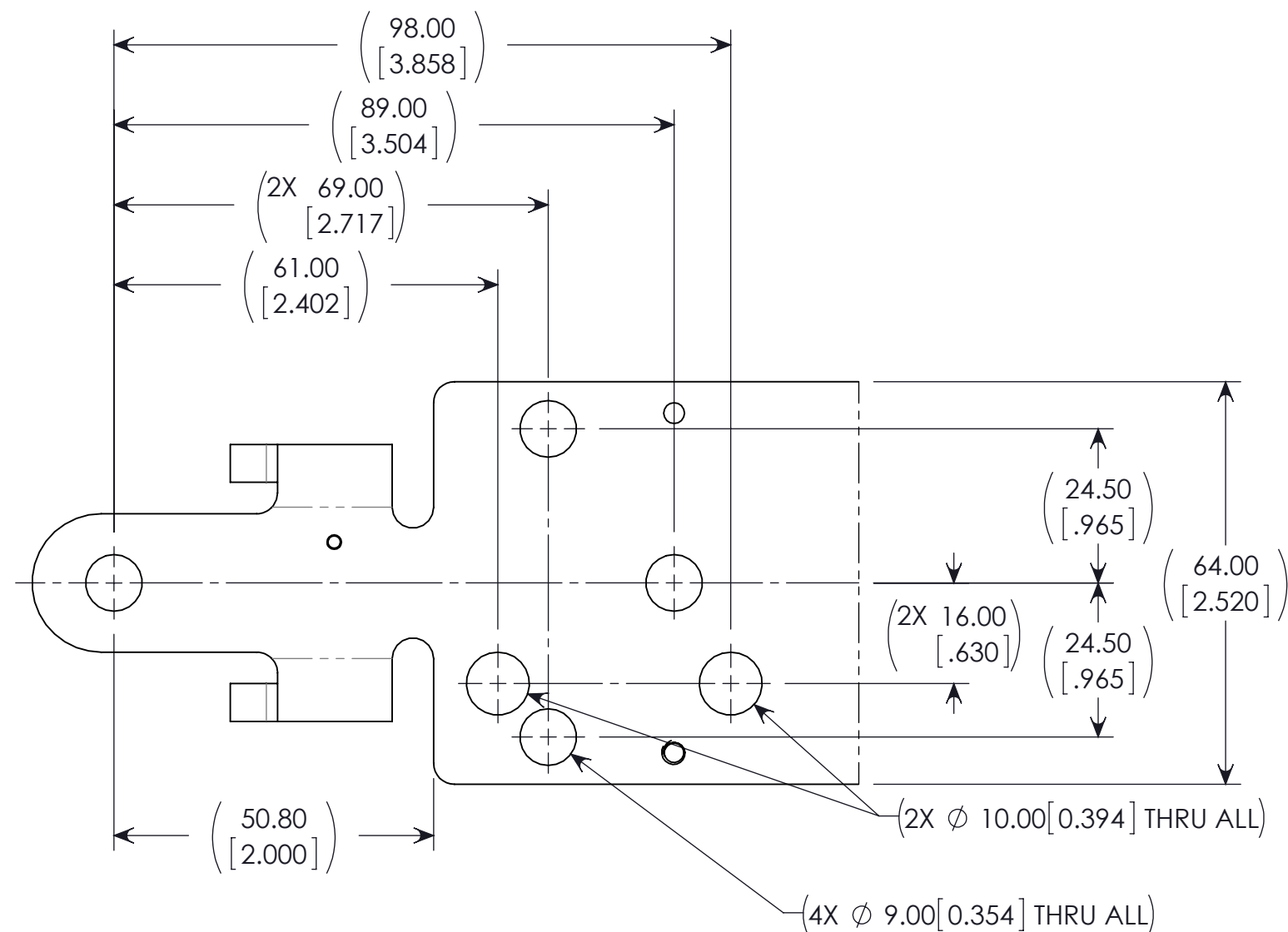

DETAIL A
 SCALE 1 : 1

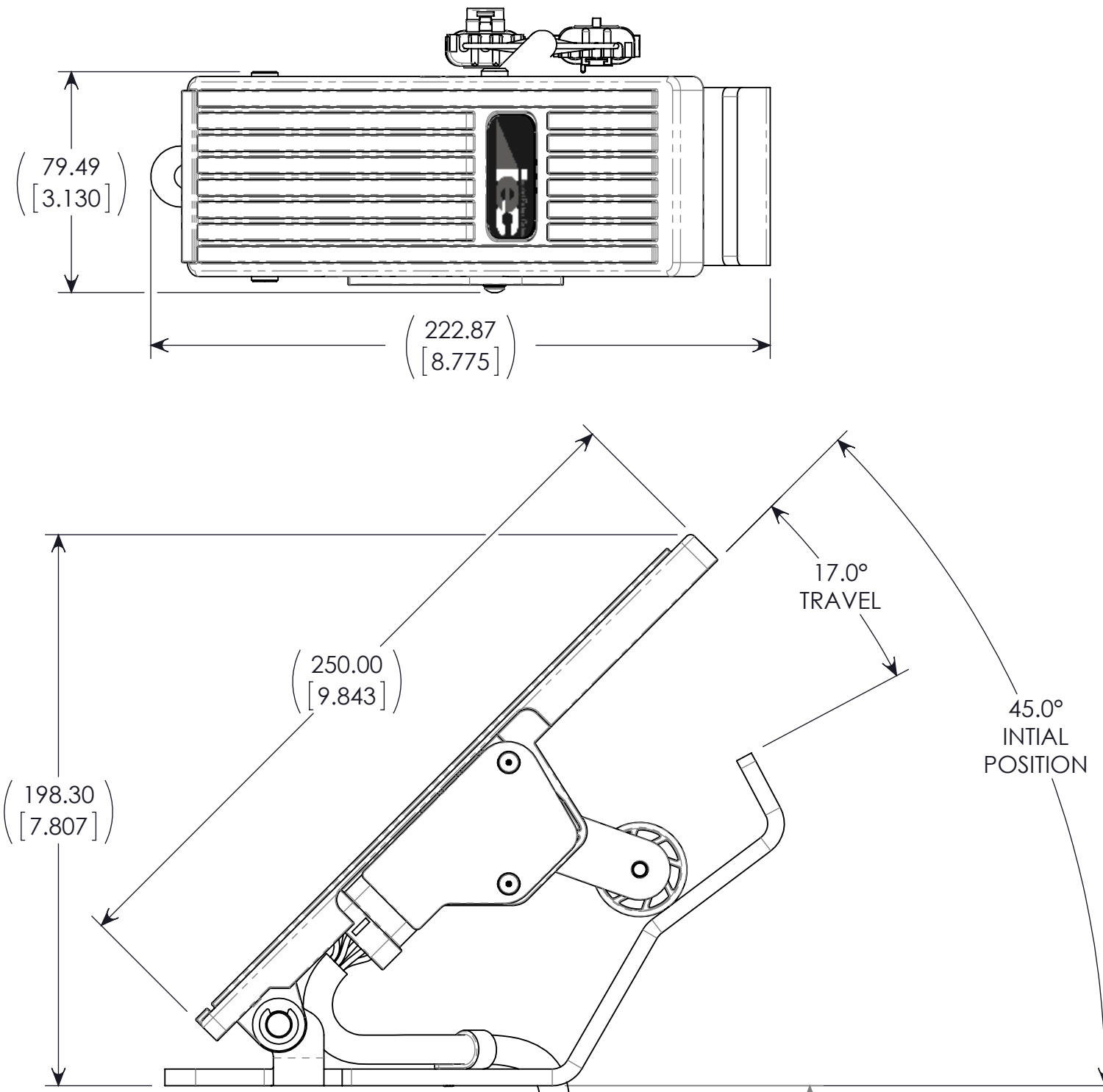

PACKARD WEATHER PACK CONNECTOR
 CONNECTOR: 1X 12015793
 TERMINAL: 3X 12089188
 WIRE SEAL: 3X 15324982 OR 15324985

CONNECTOR 12015793 PINOUT	
PIN	FUNCTION
A	OUTPUT 2
B	GROUND 2
C	SUPPLY 2 (5V)

900.35±5.00
 [35.447±.197]

DELPHI WEATHER PACK CONNECTOR
 CONNECTOR: 1X 12010717
 TERMINAL: 3X 12089040
 WIRE SEAL: 3X 15324982 OR 15324985

CONNECTOR 12010717 PINOUT	
PIN	FUNCTION
A	GROUND 1
B	OUTPUT 1
C	SUPPLY 1 (5V)

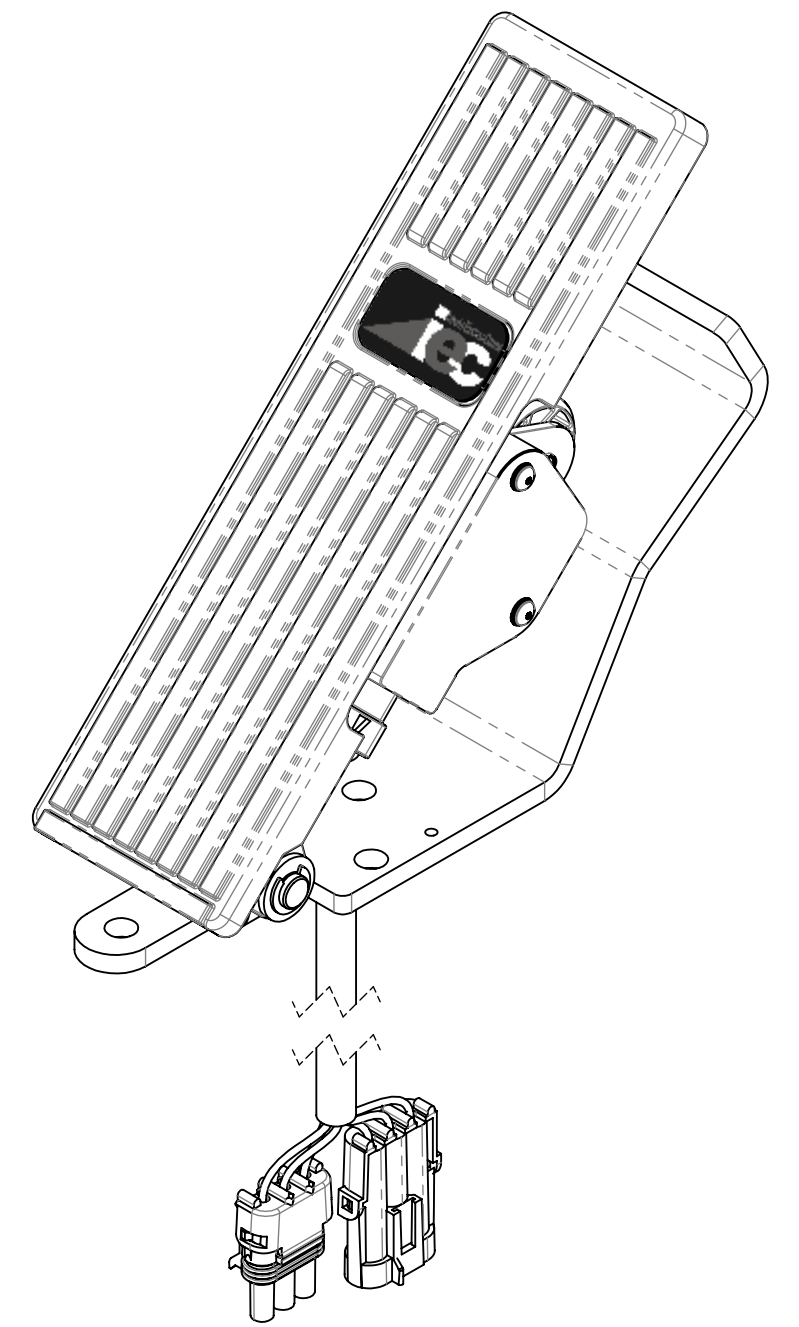
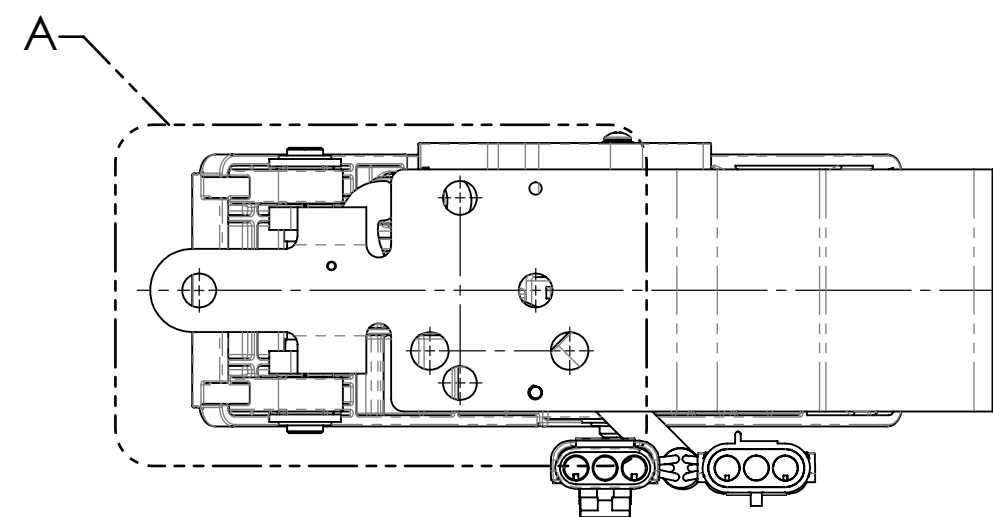

SPECIFICATIONS:

1. GENERAL REQUIREMENTS
 - IN ACCORDANCE WITH SAE J1843
 - IN ACCORDANCE WITH FMVSS124

2. ENVIRONMENTAL DATA
 - WORKING TEMPERATURE: -40°C TO +85°C
 - STORAGE TEMPERATURE: -50°C TO +120°C

3. ELECTRICAL DATA
 - INPUT VOLTAGE: 5.0V ±0.1
 - MAXIMUM CURRENT: ≤ 10MA
 - INDEPENDANT LINEARITY: 2%
 - OUTPUT SIGNALS: SEE FIGURE 1

4. MECHANICAL DATA
 - MAXIMUM LOAD: 160±5 KGF

5. MATERIAL
 - PEDAL: BLACK NYLON 6/6 30% GLASS FILLED
 - BOTTOM PLATE: ZINC PLATED STEEL
 - WIRE: AEX OR AVX 0.5 mm²

6. DURABILITY
 - LIFE CYCLE TEST: 10,000,000 CYCLES AT A FREQUENCY OF 60 TIMES PER MINUTE

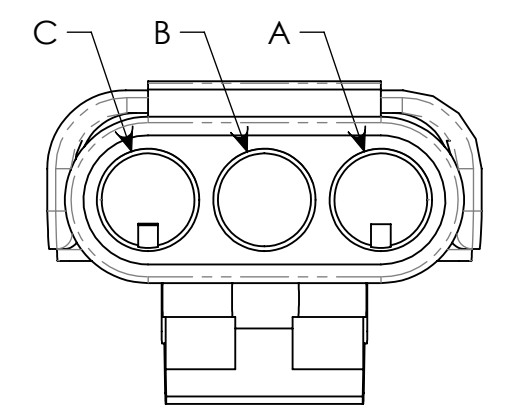
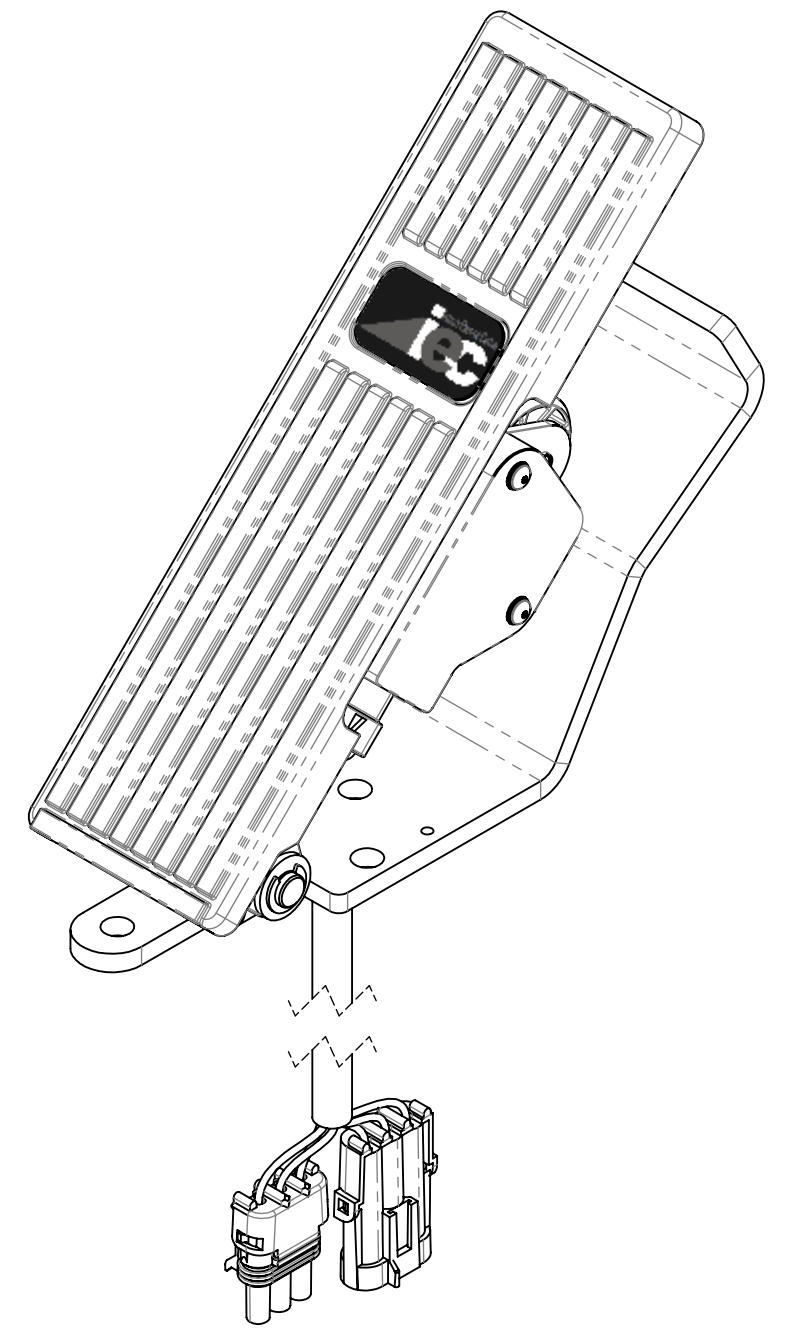
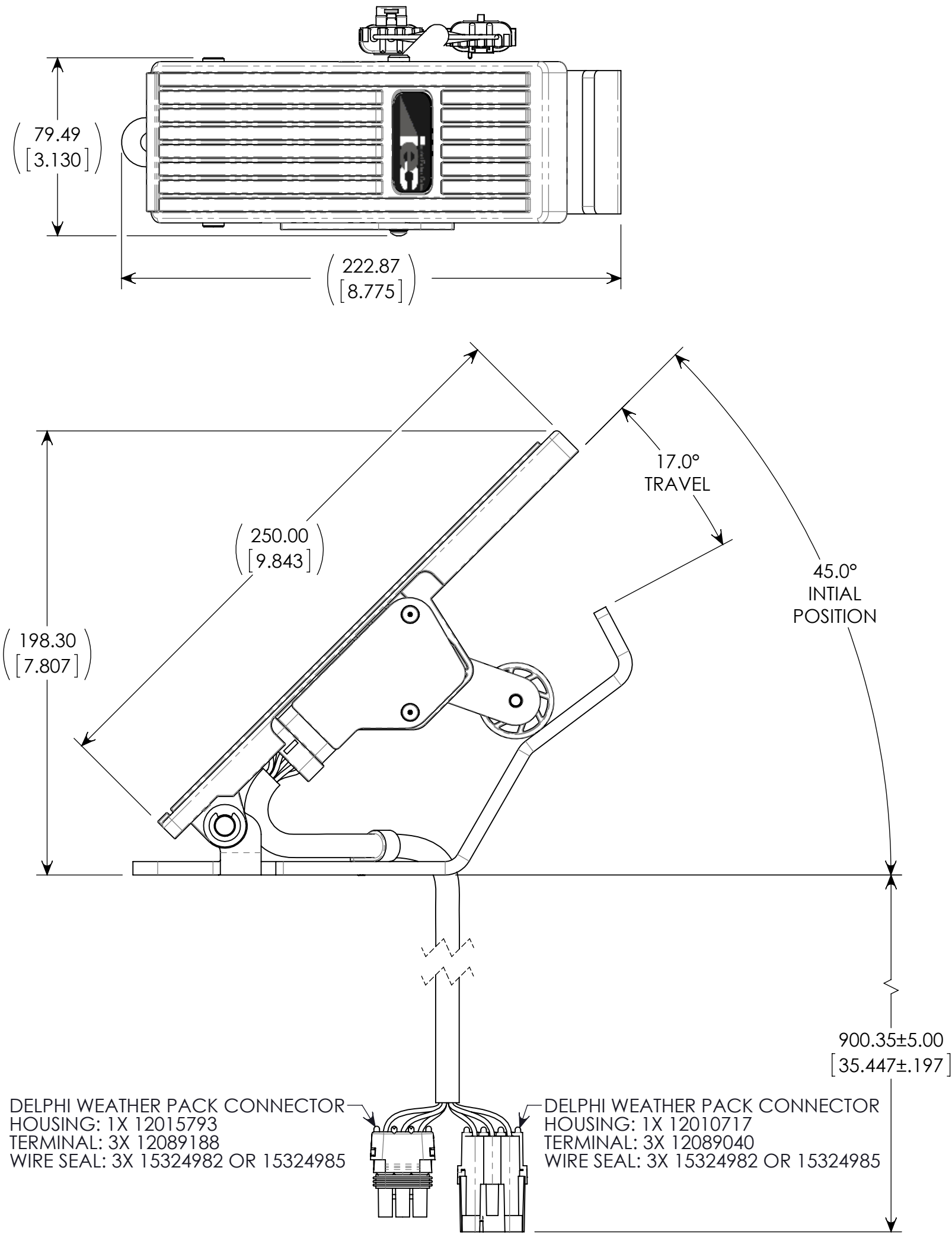
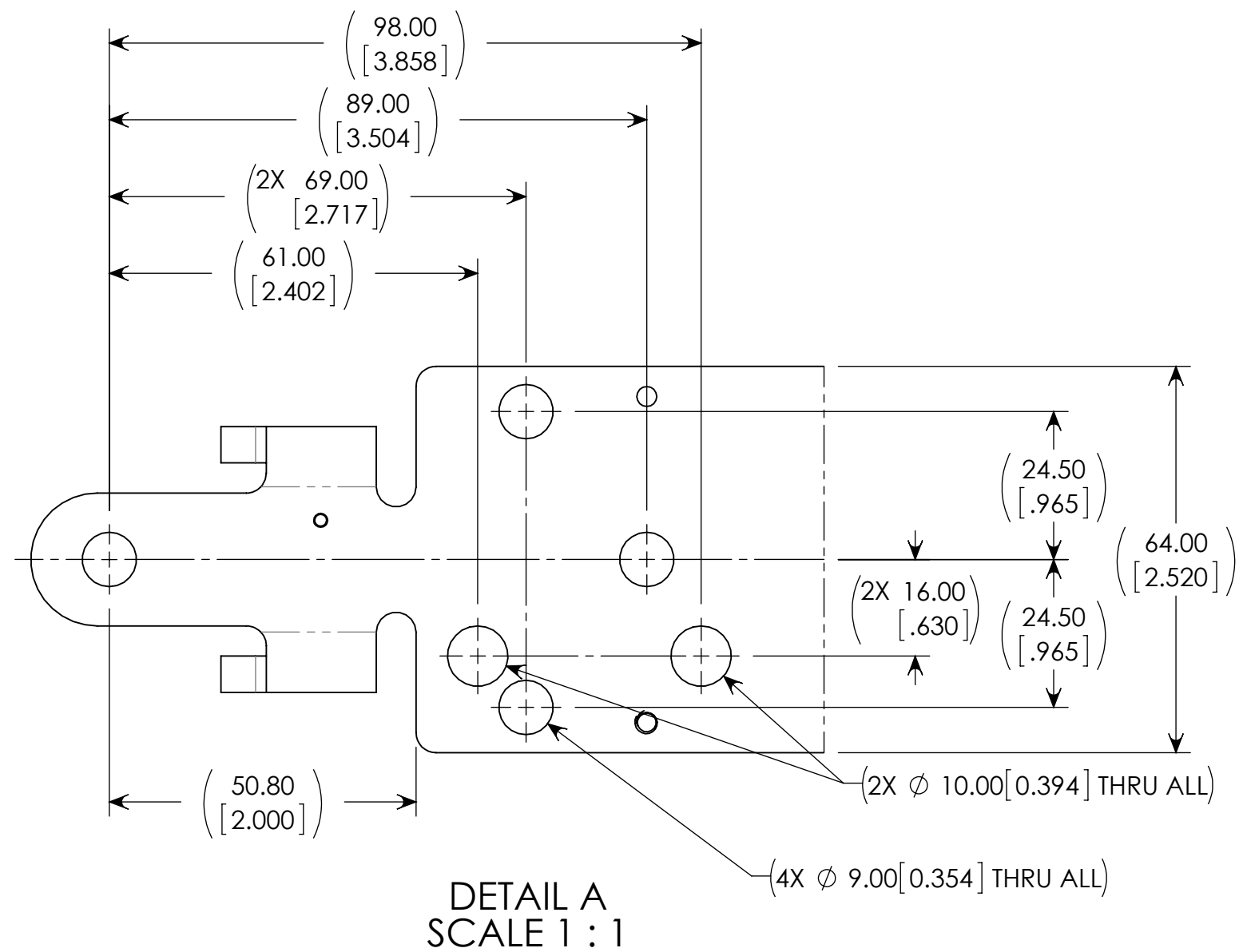
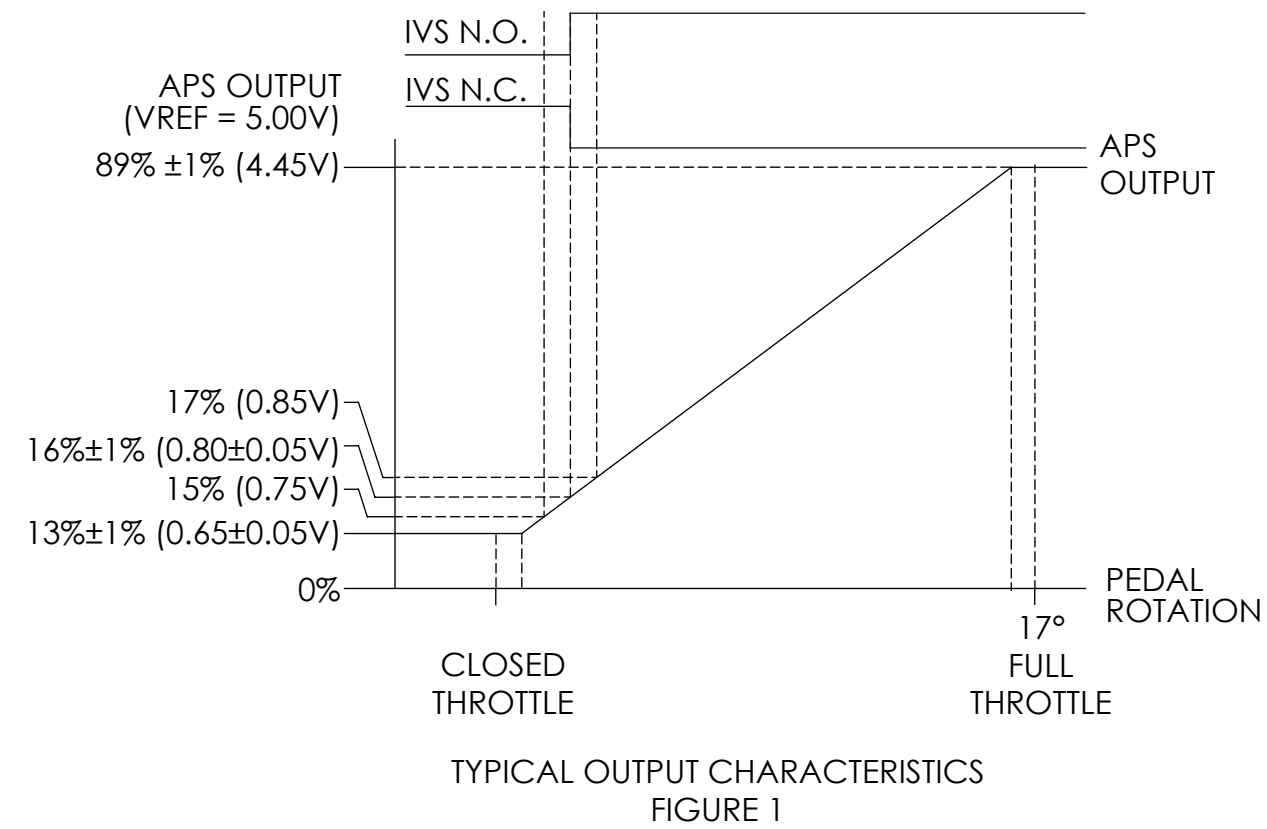

DELPHI 12015793 PINOUT		
PIN	COLOR	FUNCTION
A	ORG	IVS VCC (+5V)
B	BLU	IVS NC (IDLE)
C	GRN	IVS NO (THROT)

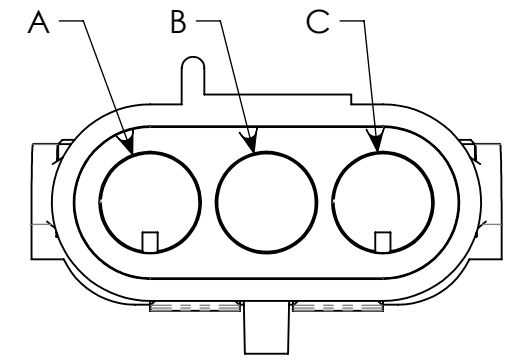

DELPHI 12010717 PINOUT		
PIN	COLOR	FUNCTION
A	WHT	GND
B	BLK	APS
C	RED	VCC (+5V)